



## Effect of internal on phase holdups of a three-phase fluidized bed

K.V. Ramesh<sup>a,\*</sup>, G.M.J. Raju<sup>a</sup>, G.V.S. Sarma<sup>a</sup>, C. Bhaskara Sarma<sup>b</sup>

<sup>a</sup> Department of Chemical Engineering, Andhra University, College of Engineering, Visakhapatnam 530 003, India

<sup>b</sup> Department of Chemical Engineering, GVP College of Engineering, Visakhapatnam 530048, India

### ARTICLE INFO

#### Article history:

Received 29 March 2007

Received in revised form 12 August 2008

Accepted 24 August 2008

#### Keywords:

Three-phase fluidized bed

Gas–liquid–solid fluidized bed

Phase

Holdups

Gas holdup

Turbulent promoter

### ABSTRACT

Individual phase holdups are important dynamic parameters in the designing of three-phase fluidized bed systems. The system chosen for the present study is nitrogen as gaseous phase, an electrolyte as liquid phase and glass balls as solid phase. The gas holdup was obtained from pressure drop measurements. The obstruction area of flow path was calculated by considering all the geometric parameters of the composite promoter for evaluating the actual velocity of the fluids through the test section. It is found that the presence of composite promoter has not shown any effect on pressure drop in three-phase fluidized beds. The bed porosity data fitted well with Richardson–Zaki equation with an exponent of 2.53. The infinite dilution velocities were increased significantly because of the presence of promoter. The data on gas holdup, liquid holdup and bed porosity were in good agreement with correlations reported earlier [S.D. Kim, C.G.J. Baker, M.A. Bergougnou, Phase holdup characteristics of three phase fluidized beds, *Can. J. Chem. Eng.* 53 (1975) 134–139; P. Dakshinamurthy, V. Subrahmanyam, K. Veerabhadra Rao, *Indian Chem. Eng.* 16 (1974) 3; W.Y. Soung, Bed expansion in three-phase fluidization, *Ind. Eng. Chem. Proc. Des. Dev.* 17 (1978) 33; S.R. Bloxom, J.M. Costa, J. Herranz, G.L. MacWilliam, S.R. Roth, Determination and correlation of hydrodynamic variables in three-phase fluidized bed, ORNL/MIT-219, Oak Ridge National Lab. (1975)].

© 2008 Elsevier B.V. All rights reserved.

### 1. Introduction

Three-phase fluidization [1–3] is considered to be one of the vital methods of multiphase flow contacting operation. Increased improvements in heat and mass transfer coefficients were observed in comparison with two-phase and homogeneous flow systems in general. Further, it provides intimate mixing, isothermal conditions, uniform concentrations, high heat and mass transfer rates, high liquid holdup, ability to use small catalyst particles, accurate temperature control to achieve good selectivity and increased protection of catalyst, etc. Hence it finds wide applications in petrochemical industries, chemical and allied industries, and in biochemical processing.

It has been widely reported that the performance factors of several heat and mass transfer systems have been greatly enhanced with the use of turbulence promoters. A comprehensive review on the techniques and types of promoters, which have been in practice, was presented by Bergles [4].

The gas and liquid holdups are most important design parameters in three-phase fluidized beds. These phase holdups are affected by phase velocities, physical properties, geometry of the column,

etc. No systematic study on the effect of the presence of an internal on phase holdups in three-phase fluidized beds has been reported in the literature [5,6].

### 2. Experimental apparatus and procedure

The bed internal and the equipment were designed and fabricated to carryout studies on phase holdups, the schematic diagrams of which were shown in Fig. 1a and b respectively. Coaxially placed twisted tapes wound on a rod were used as composite promoters. The system chosen was a fluid electrolyte–nitrogen gas–glass balls. The electrolyte was an equimolar solution of potassium ferri-cyanide and potassium ferrocyanide each of 0.01 N with 0.5 N sodium hydroxide. The system is maintained at a constant temperature of 30 °C. At this temperature the density and viscosity of the liquid electrolyte are taken as 1023 kg/m<sup>3</sup> and 0.896 cP, respectively. Flow rates of fluid electrolyte and nitrogen gas were measured by the pre-calibrated rotameter and wet gas meter, respectively. A U-tube differential manometer was provided to measure the pressure difference across the test section. A stainless steel wire mesh was placed at the bottom of the test section to support the bed of solids and allow the distribution of liquid and gas during fluidization. The composite promoter element shown in Fig. 1b was essentially a copper or stainless steel rod of diameter  $d_r$ , on the outer surface of which, a tape of given width  $w$ , thickness  $t$

\* Corresponding author. Tel.: +91 9490109683.

E-mail address: [kvramesh69@yahoo.com](mailto:kvramesh69@yahoo.com) (K.V. Ramesh).

**Nomenclature**

$A$	cross-sectional area of test section ( $\text{m}^2$ )
$d_p$	particle diameter (m)
$d_r$	diameter of rod on which tape was wound (m)
$D_c$	column diameter (m)
$D_e$	equivalent diameter (m)
$g$	acceleration due to gravity ( $\text{m/s}^2$ )
$H$	height of test section or bed height (m)
$n$	Richardson–Zaki exponent
$p$	pitch of the tape (m)
$\Delta P$	pressure drop across test section (Pa)
$\Delta P''$	pressure drop across test section in liquid solid fluidized bed (Pa)
$\Delta P'''$	pressure drop across test section in three-phase fluidized bed (Pa)
$Q_g$	volumetric flow rate of gas ( $\text{m}^3/\text{s}$ )
$Q_L$	volumetric flow rate of liquid ( $\text{m}^3/\text{s}$ )
$Re_p$	particle Reynolds number
$t$	thickness of the tape (m)
$U_g$	superficial gas velocity (m/s)
$U_{go}$	axial gas velocity based on obstruction diameter (m/s)
$U_L$	superficial liquid velocity (m/s)
$U_{Lo}$	axial liquid velocity based on obstruction diameter (m/s)
$U_t$	terminal velocity of particle (m/s)
$w$	width of the tape (m)
$W_s$	weight of solids (kg)

**Greek letters**

$\varepsilon$	bed porosity
$\varepsilon_g$	gas holdup
$\varepsilon_L$	liquid holdup
$\varepsilon_s$	solids holdup
$\mu_L$	liquid viscosity ( $\text{kg/m s}$ )
$\rho_L$	density of liquid ( $\text{kg/m}^3$ )
$\sigma$	surface tension (N/m)

was wound and brazed helicoidally at a desired pitch  $p$ . Composite promoter elements of different geometrical characteristics (viz., diameter  $d_r$ , pitch  $p$  and width  $w$ ) were fabricated and used in the present study. Three rod diameters of 1.27, 1.59 and 1.9 cm, four tape widths of 0.3, 0.6, 0.9 and 1.2 cm, and five tape pitches of 1, 2, 3, 5 and 14.5 cm were chosen as geometrical parameters of the promoter element. The ranges of variables covered along with the geometrical characteristics of the promoter assemblies used were presented in Table 1.

In a multiphase system, the holdup of a phase is defined as the ratio of the volume of the phase to the total volume of the system.

**Table 1**  
Ranges of variables studied

S. no.	Parameters studied	Minimum	Maximum
1	Flow rate of gas, $Q_g \times 10^3$ ( $\text{m}^3/\text{s}$ )	0	0.418
2	Flow rate of liquid, $Q_L \times 10^3$ ( $\text{m}^3/\text{s}$ )	0.308	0.875
3	Diameters of the rod on which the tape is wound, $d_r$ (cm)	1.27	1.90
4	Pitch of the promoter element, $p$ (cm)	1.0	14.5
5	Width of the promoter element, $w$ (cm)	0.3	1.2
6	Diameter of the particle, $d_p$ (mm)	3.13	6.29
7	$Re$	1065	18,900
8	$Re_p$	72.3	2,087

The solids holdup,  $\varepsilon_s$  was determined from bed height measurements using the equation [7]:

$$\varepsilon_s = \frac{W_s}{\rho_s A H} \quad (1)$$

The gas holdup was determined from the pressure drop measurements using the equation [7]:

$$\varepsilon_g = \frac{\Delta P'' - \Delta P'''}{g H \rho_L} \quad (2)$$

The liquid hold up was obtained from the equation [7]:

$$\varepsilon_L = 1 - \varepsilon_s - \varepsilon_g \quad (3)$$

**3. Results and discussion**

Comparative pressure drop data both in the two-phase and three-phase fluidized beds have been shown in Fig. 2. Presence of promoter in a two-phase fluidized bed has shown considerable increase in the pressure drop (plots C and D) while in a three-phase fluidized bed, the presence of promoter has not shown much effect on the pressure drop (plots A and B).

Bed expansion behavior in two-phase liquid–solid fluidized beds was generally expressed as [8]:

$$\frac{U_L}{U_t} = \varepsilon^n \quad (4)$$

For a given particle, the terminal velocity being constant, the functional relationship between  $U_L$  and  $\varepsilon$  can be expressed as

$$Re_p \propto \varepsilon^n \quad (5)$$

In two-phase liquid–solid systems Richardson and Zaki [8] showed that for  $Re_p > 500$  in the absence of any bed internal,  $n$  takes a value of 2.39. Sujatha et al. [9] reported the same value in liquid–solid system even in the presence of a helicoidal tape promoter. An attempt has been made to check the validity of Richardson and Zaki [8] correlation for the present data in three-phase system with a bed internal. Fig. 3 shows the effect of  $Re_p$  on bed voidage for three different gas velocities for one particle size. The data were found to be consistent with a slope of 2.53 compared to that of 2.39 reported in liquid–solid systems. The deviation can be due to the presence of the third phase. The effect of promoter with three different bed particles was also plotted and shown in Fig. 4. The effect of particle size is conspicuous, however, the slope in each case was found to be 2.53 same as that in Fig. 3 indicating that the presence of promoter has not affected the exponent on  $\varepsilon$ . An attempt was made to correlate the entire data on bed expansion obtained in the present experiment. The correlation yielded a value of 2.53 for  $n$  with an average deviation of 18%.

Introduction of gas into a liquid–solid fluidized bed leads to increased turbulence. In three-phase fluidized beds the intense churning action is essentially due to the following reasons: (i) the resistance offered to the upward gas flow by the bed, (ii) the bubble disintegration on breaking up of large bubbles into small bubbles and (iii) scattering of the disintegrated bubbles promoting efficient dispersion of bubbles. However, at low gas velocities, the bubbles passing through the bed of solids coalesce to give rise to large bubbles while at high gas velocities the bubble disintegration is favored. During the bubble disintegration regime, the solid particles uniformly get distributed in the bed. The presence of an internal favors bubble disintegration phenomenon thus assuring the uniform bed expansion.

The effect of presence of promoter on bed expansion behavior in a three-phase fluidized bed is also shown in Fig. 5 in terms of

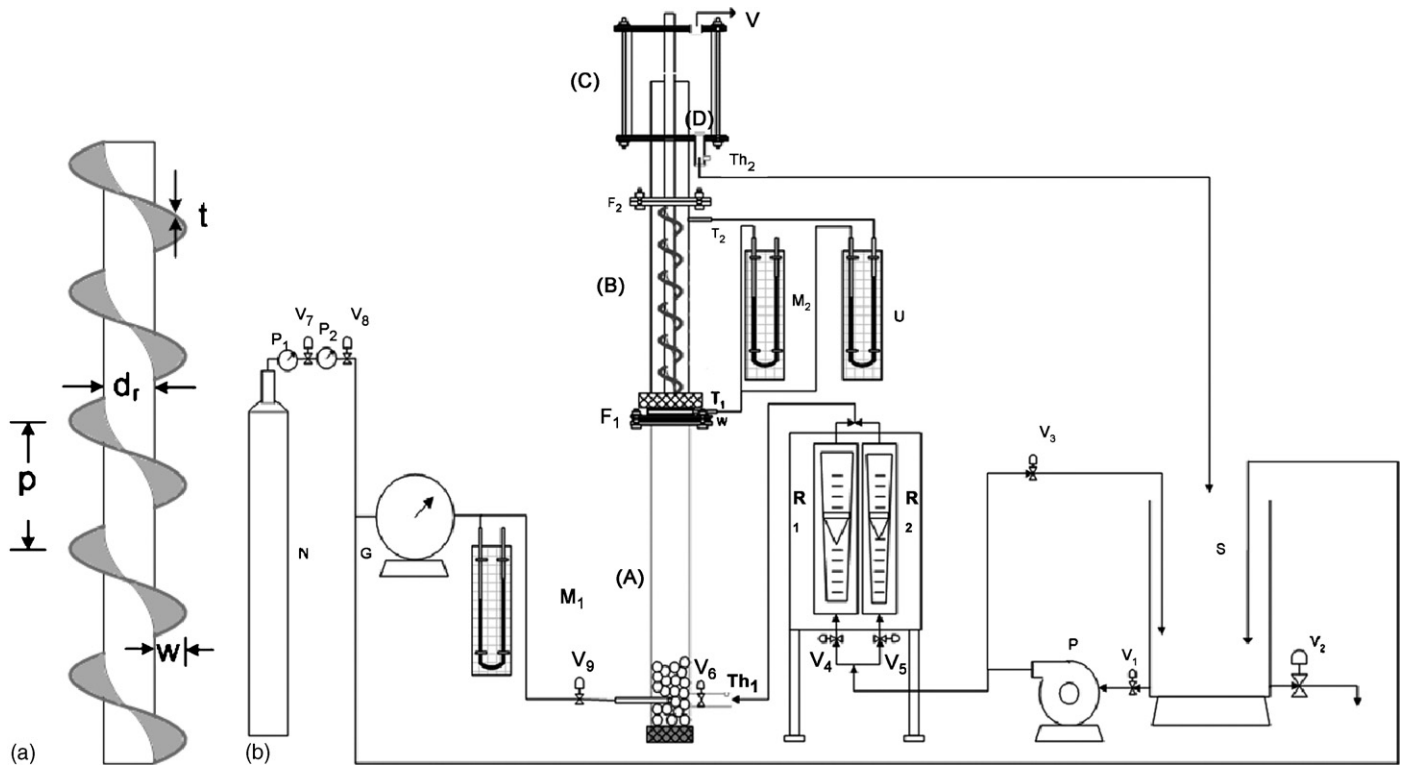

Fig. 1. (a) Schematic of the turbulent promoter. (b) Schematic of the experimental unit.

voidage function  $(1 - \epsilon)/\epsilon^3$ . For the same flow rate, bed without promoter was approaching infinite dilution condition while in the presence of promoter the infinite dilution velocity has been considerably raised maintaining its fluidized bed status. The data in Fig. 5 shows that the infinite dilution velocity in the absence of promoter was found to be 25 cm/s while it had been significantly increased by 20% (liquid velocity = 30 cm/s) in the presence of promoter. Therefore the fluidized bed condition could be maintained over a wide range of flow rates/velocities. The presence of promoter was found to be advantageous as it has raised the infinite dilution velocities in a three-phase fluidized bed, thus limiting the carry-over elutriation of fluidizing particles.

The axial velocities of both the liquid and gas (dispersed) are assumed to be responsible for whatever dynamic changes that are occurring in the three-phase fluidized beds. The presence of

promoter internal would occupy considerable volume of the test section obstructing the flow path for liquid and gas. The local gas and liquid velocities prevailing would significantly differ from the superficial velocity based on empty conduit cross-section and need considerable attention.

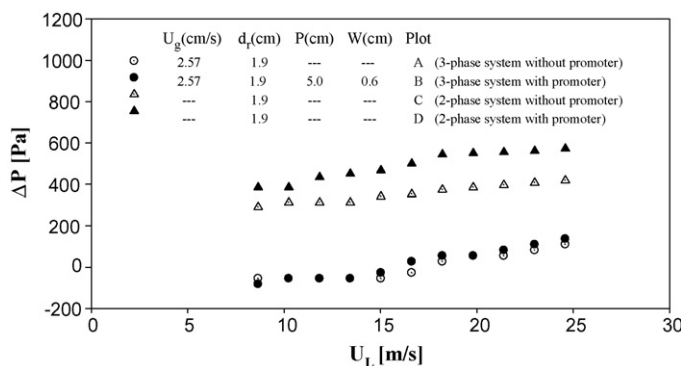

Fig. 2. Variation of pressure drop with superficial liquid velocity for  $d_p = 4.57$  mm both in the absence and presence of promoter.

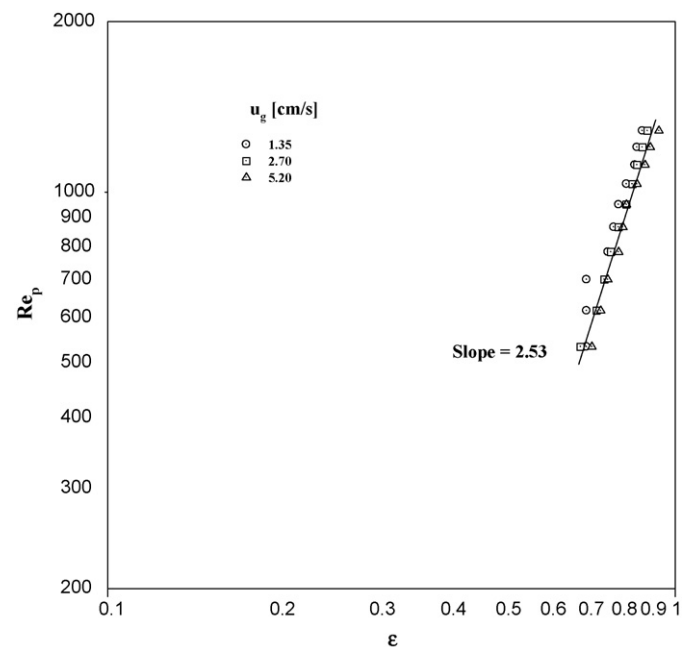
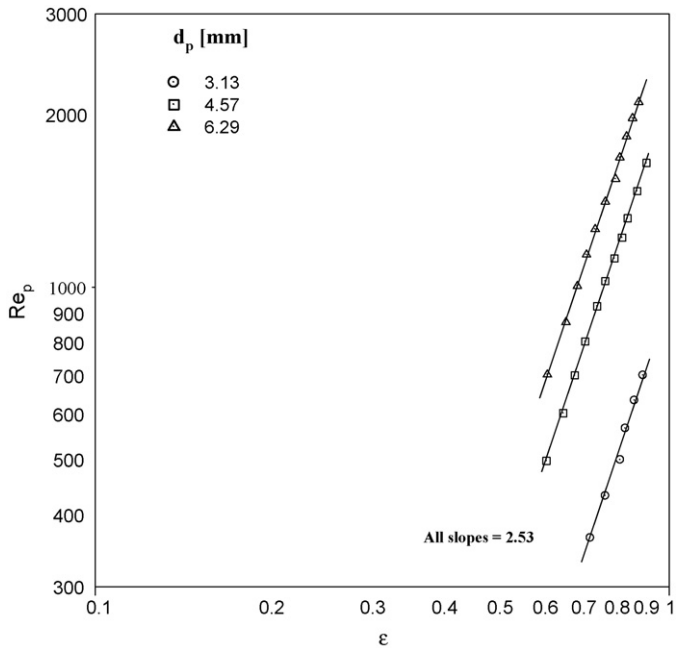

Fig. 3. Variation of  $Re_p$  with bed porosity  $\epsilon$  for  $d_p = 4.57$  mm in the absence of promoter.

**Table 2**  
Correlations proposed by earlier investigators tested with the present experimental data

S. no.	Reference	Equation	Avg. deviation of present data (%)
1	Kim et al. [10]	$\epsilon = 1.4 \left( \frac{U_g^2}{g d_p} \right)^{0.17} \left( \frac{U_g \mu}{\sigma} \right)^{0.078}$	8.70
2	Dakshinamurthy et al. [11]	$\epsilon_g = 1.61 \times 10^3 \left( \frac{d_p \rho_L U_t}{\mu_L} \right)^{-0.188} \left( \frac{U_g \mu_L}{\sigma} \right)^{1.066}$	13.3
3	Soung [12]	$\epsilon_g = 0.0021 \left( \frac{U_g}{\sqrt{g D_c}} \right)^{0.82} \left( \frac{g D_c^2 \rho_L}{\sigma} \right)^{0.8} \left( \frac{g D_c^3 \rho_L}{\mu_L} \right)^{0.1}$	16.3
4	Bloxom et al. [13]	$\epsilon_L = 1310 U_L^{0.269} U_g^{-0.146} (\rho_s - \rho_L)^{-1.072}$	13.0



**Fig. 4.** Variation of particle Reynolds number with bed porosity in the presence of promoter  $\{d_r = 1.9 \text{ cm}, p = 5 \text{ cm}, w = 0.9 \text{ cm}\}$ .

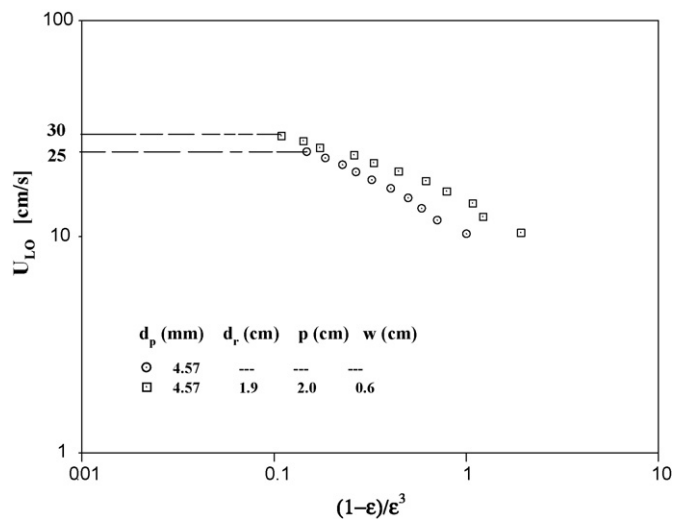

**Fig. 5.** Variation of velocity with voidage function ( $U_g = 2.7 \text{ cm/s}$ )—effect of promoter on infinite dilution.

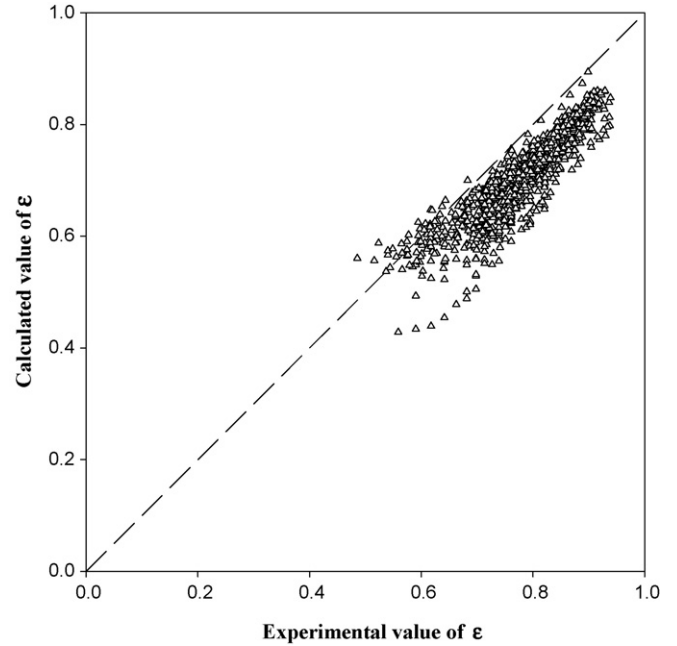

**Fig. 6.** Comparison of present experimental data on bed porosity with that of Kim et al. [10].

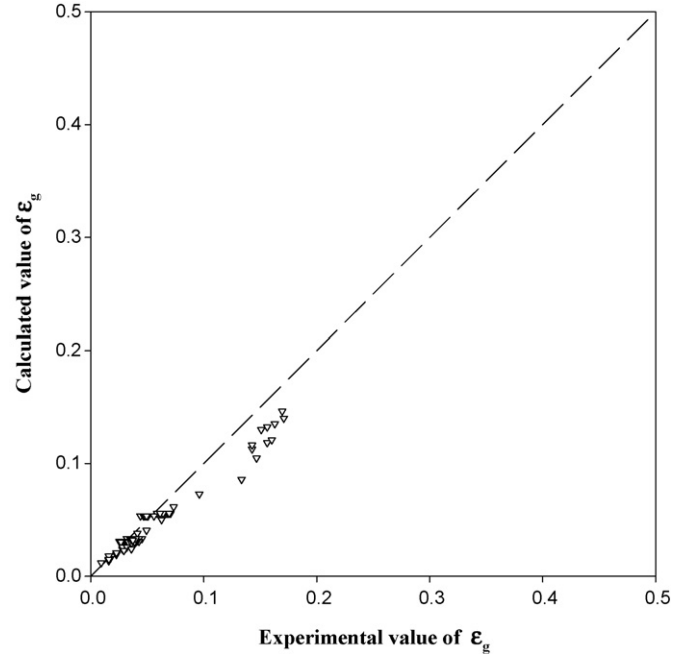

**Fig. 7.** Comparison of present experimental data on gas holdup with that of Dakshinamurthy et al. [11].

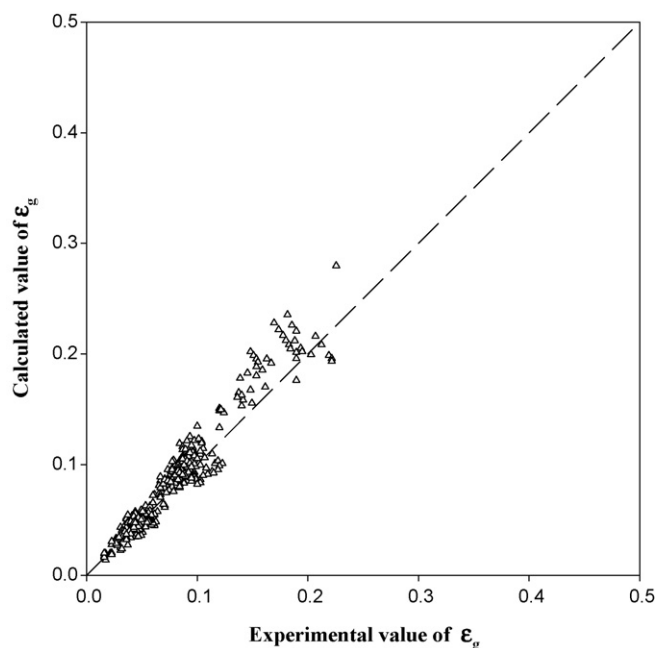

Fig. 8. Comparison of present experimental data on gas holdup with the calculated data based on Soung [12].

Eq. (6) has been derived considering all the geometrical variables in the present investigation:

$$D_e = \frac{\pi(D_c^2 - d_r^2) - 2wt \left[ \sqrt{1 + (\pi d_r/p)^2} + \sqrt{1 + (\pi(d_r + 2w)/p)^2} \right]}{\pi(D_c + d_r) + w \left[ \sqrt{1 + (\pi d_r/p)^2} + \sqrt{1 + (\pi(d_r + 2w)/p)^2} \right]} - t \left[ \sqrt{1 + (\pi d_r/p)^2} - \sqrt{1 + (\pi(d_r + 2w)/p)^2} \right] \quad (6)$$

The obstruction diameter is  $D_o = D_c - D_e$  (7)

Available area for flow =  $\frac{\pi D_c^2}{4} - \frac{\pi D_o^2}{4}$  (8)

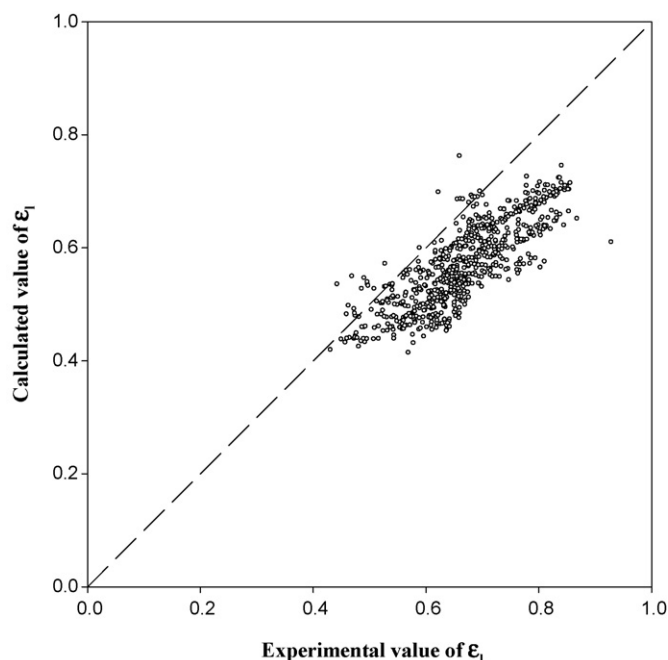

Fig. 9. Comparison of present experimental data on liquid holdup with the calculated data based on Bloxom et al. [13].

Therefore liquid superficial velocity based on obstruction area is

$$U_{Lo} = \frac{4Q_L}{\pi(D_c^2 - D_o^2)} \quad (9)$$

And, gas superficial velocity based on obstruction area is

$$U_{go} = \frac{4Q_g}{\pi(D_c^2 - D_o^2)} \quad (10)$$

The mean axial fluid velocities thus obtained were used to test the correlations already reported in literature. The data on gas holdup, liquid holdup and bed porosity calculated from the correlations proposed earlier and the present experimental data were shown through the plots of Figs. 6–9. The present experimental data on phase holdups and bed porosities were found to be well comparable to those of the earlier investigators and the results were shown compiled in Table 2.

#### 4. Conclusions

- The presence of composite promoter raised the infinite dilution velocity yielding a high bed porosity value.
- The bed porosity data of three-phase fluidized bed, could be correlated by the Richardson and Zaki [8] equation within an average deviation of 18%. The exponent on the voidage was found to be 2.53, which is comparable as against 2.39 reported for two-phase fluidized beds.

- The present experimental data on gas holdup and liquid holdup and bed porosity were in good agreement with the equations proposed by earlier investigators [10–13].

#### Acknowledgements

The authors gratefully acknowledge the UGC, New Delhi as this work was financially supported by Phase-III of SAP, Dept. of Chemical Engineering, Andhra University.

#### Appendix A. Supplementary data

Supplementary data associated with this article can be found, in the online version, at doi:10.1016/j.cej.2008.08.023.

#### References

- [1] L.-S. Fan, Gas–liquid–Solid Fluidization Engineering, Butterworths, Stoneham, MA, 1989.
- [2] K.V. Ramesh, Liquid-to-wall Mass Transfer in the Absence and Presence of a Composite Promoter, Ph.D. Thesis, Andhra University, Visakhapatnam, India (2006).
- [3] K.V. Ramesh, G.M.J. Raju, C. Bhaskara Sarma, R.V. Subba Raju, Liquid-wall mass transfer in three phase fluidized beds with cross-flow of electrolyte, Chem. Eng. J. 135 (2008) 224–231.
- [4] A.E. Bergles, Keynote at the 5th International Conference on Boiling Heat Transfer, Montego Bay, Jamaica, May 4–8, 2003.
- [5] S.D. Kim, Y. Kang, Heat and mass transfer in three-phase fluidized-bed reactors—an overview, Chem. Eng. Sci. 52 (1997) 3639–3660.
- [6] K.V. Ramesh, G.M.J. Raju, G.V.S. Sarma, C. Bhaskara Sarma, Phase holdups and bed porosity in three-phase fluidized beds with an internal, in: Proceedings of International Conference CFEMATCON-06, Andhra University, Visakhapatnam, India, 2006.
- [7] N. Epstein, Three-phase fluidization: some knowledge gaps, Can. J. Chem. Eng. 59 (1981) 649–657.

- [8] J.F. Richardson, W.N. Zaki, Sedimentation fluidization. Part I, *Trans. Instn. Chem. Eng.* 32 (1954) 35–53.
- [9] V. Sujatha, P. Rajendra Prasad, C. Bhaskara Sarma, G.J.V. Jagannadha Raju, Studies on ionic mass transfer with insert helical tape promoters in batch fluidized beds, *Indian J. Chem. Technol.* 10 (2003) 694–700.
- [10] S.D. Kim, C.G.J. Baker, M.A. Bergougnou, Phase holdup characteristics of three phase fluidized beds, *Can. J. Chem. Eng.* 53 (1975) 134–139.
- [11] P. Dakshinamurthy, V. Subrahmanyam, K. Veerabhadra Rao, *Indian Chem. Eng.* 16 (1974) 3.
- [12] W.Y. Soung, Bed expansion in three-phase fluidization, *Ind. Eng. Chem. Proc. Des. Dev.* 17 (1978) 33.
- [13] S.R. Bloxom, J.M. Costa, J. Herranz, G.L. MacWilliam, S.R. Roth, Determination and Correlation of Hydrodynamic Variables in Three-phase Fluidized Bed, ORNL/MIT-219, Oak Ridge National Lab, 1975.